

Standardizing luminaire technologies with D4i



September 2019

Jens Herter - TRIDONIC

Head of Global Certification, Standardization & Funding



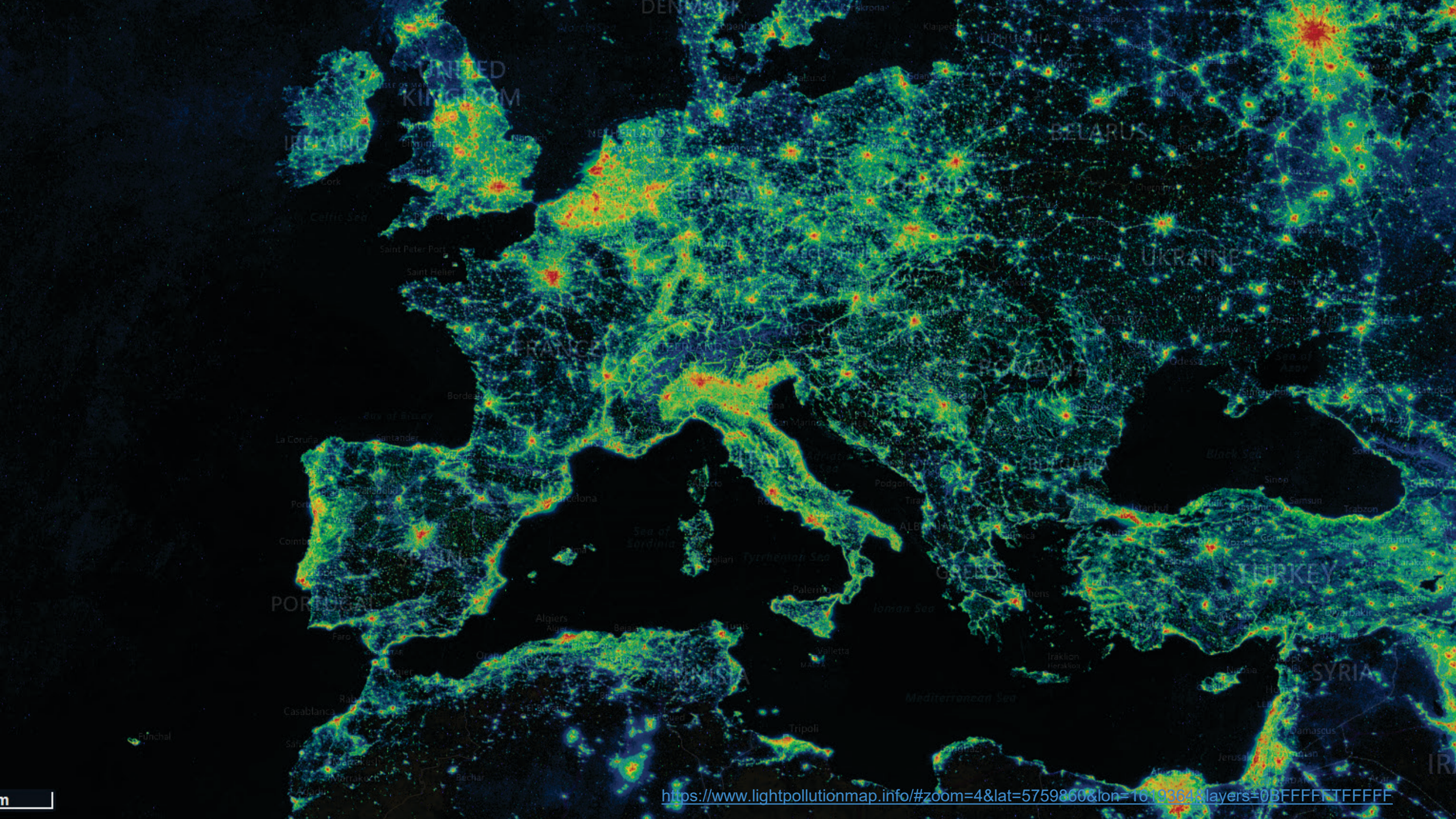

<https://www.lightpollutionmap.info/#zoom=4&lat=5759860&lon=1619382&layers=0BFFFFTFFFF>

m

Fulda – “Sternen Stadt” Stars City

Fulda is the first “Stars City” in Germany

- LED Lighting
- Timing control
- Dimming
- Presence detection
- On / Off

- Too much non controlled light
- Cold light
- Demand driven light
- Reduction of cost
- No compromises on comfort and security

Stadtbaurat **Schreiner** ergänzte, zu viel und vor allem falsch gerichtetes, schlecht gesteuertes Licht in kalten Lichtfarben beeinträchtigt nachweislich das Leben vieler nachtaktiver Arten, stört Pflanzen und belastet die Gesundheit der Menschen. „Das muss nicht sein“, so Schreiner. Es sei leicht möglich, künstliches Licht standort- und bedarfsgerecht einzusetzen. „So kann man Lichtverschmutzung vermeiden, Kosten senken und durch Energieeinsparung einen Beitrag zum Klimaschutz leisten.“ Bei intelligentem Einsatz von künstlichem Licht ließen sich dabei Einschränkungen in Komfort und Sicherheit ausschließen.

©Christian Tech

Requested functions

Lighting on Demand



Beyond lighting

Predictive Maintenance

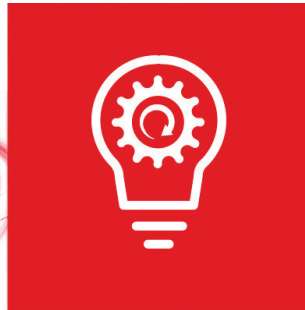

Dynamic Lighting

Market demand: Smart, future-proof LED luminaires with connectivity

Connected: Able to participate in the IoT

Future-proof: Easily upgraded to keep pace with rapid developments in digital networking technology

Standardized: Certified solutions with plug-and-play interoperability

Beyond lighting: Supporting sensing and communication applications

Intelligent: Able to collect and report a wide variety of data

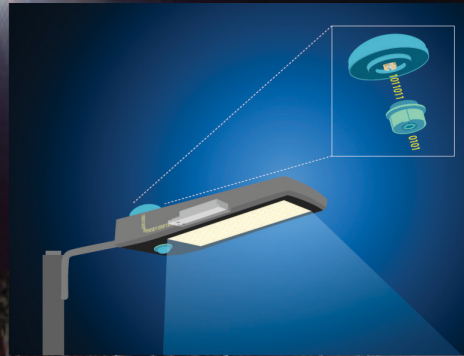

Features of D4i interface standard

- Enables **future-proof luminaires** that can keep pace with rapid developments in digital networking and sensing technology.
- Intra-luminaire DALI-2 bus:
 - Enables **bi-directional interaction** between sensors and/or communication nodes and LED drivers using the well-established and **standardized** DALI protocol.
- D4i drivers are smart:
 - Able to report **operational and diagnostic data** to an external network, and can provide inventory-related **information about the luminaires**.
- Up to **two nodes**, such as sensors, or communication devices can connect to the intra-luminaire bus.
- IoT connectivity:
 - With a suitable wireless communication node, the luminaire is able to interact with an external lighting-control network, and to participate in the IoT.

D4i specifications for intra-luminaire DALI



- Part 150/AUX power supply
- DALI Part 250 (integrated bus power supply)
- DALI Parts 251-3 (operational & diagnostic data)

www.dali2.org/d4i

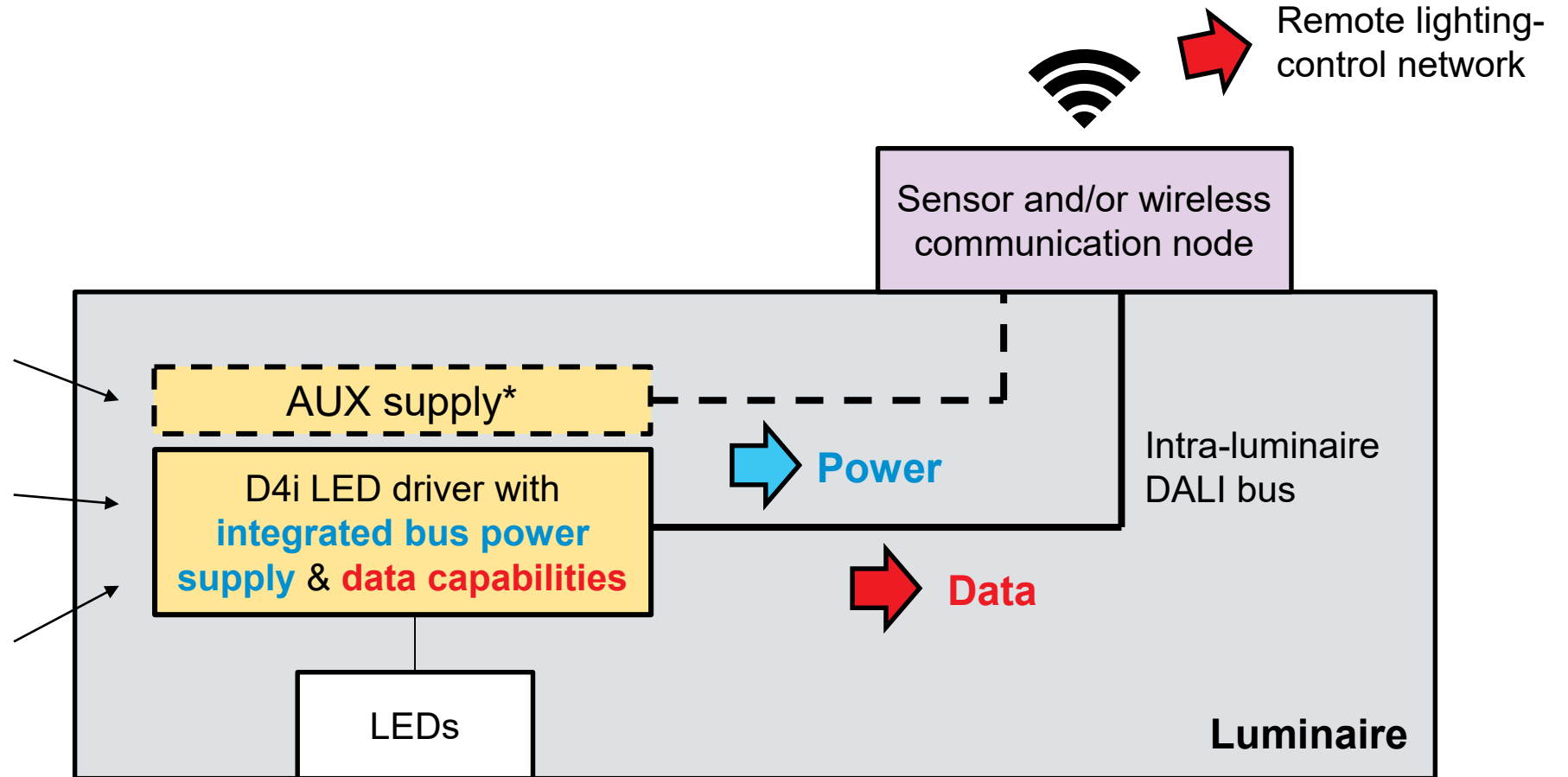

* Auxiliary (AUX) power supply can be in a driver, or implemented in a separate product.

D4i benefits for control gear (drivers)

- Compact design
- Standardized interface to sensors
- Tested and certified implementations
- Luminaire design is interoperable
- Multi sourcing for luminaire manufacturer
- Providing operational and diagnostic data

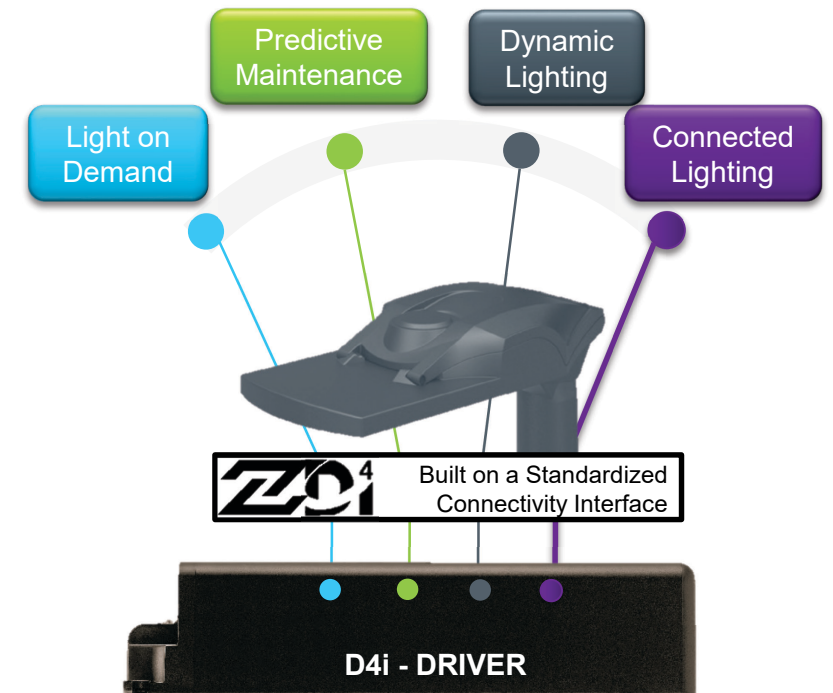

D4i benefits for control devices

- Certified control devices
- Well known Software from DALI Version 2
- Standardized protocol design
- Standardized electro mechanical design
- Field replaceable
- Multi sourcing of control devices



D4i benefits for luminaires

- Programming of luminaire identification data
- Selecting of control devices from multi vendors
- Part 150 defined power supplies for control devices
- Part 250 – 251 operational and diagnostic data
- 24V PSU for more power consumption



New: D4i certification

- **D4i certification:**
 - Control gear (drivers)
 - Control devices (nodes)
- Product certification will enable use of D4i logo
 - For **luminaires, sensors** and **communication nodes**
 - Logo indicates multi-vendor **product interoperability**
- Initial focus on **outdoor lighting**
 - Indoor solutions being developed
- Luminaires can be Zhaga-D4i certified, through a joint certification program.



Certification process: D4i devices



- 1 DiiA member (or DiiA test-house) tests the product
- 2 Results verified by DiiA. Product certified by DiiA
- 3 Certification allows use of DALI-2 and/or D4i trademark logos
 - Certified product listed in DiiA product database
- 4 D4i certification enables use of D4i logos, on product and product literature

Market requirement: plug & play interoperability of luminaires and nodes

Market requirement: Smart, future-proof LED luminaires with IoT connectivity

Solution: The **Zhaga-D4i interface standard**

→ A simple way to add sensors and/or wireless communication nodes to luminaires, with plug-and-play interoperability

- Zhaga and DiiA have collaborated to develop a standardized interface between luminaires and sensors and/or communication nodes:
 - Combining complementary specifications for mechanical fit, digital communication and power
 - Offering Zhaga-D4i certification to ensure plug-and-play interoperability
 - Focusing initially on outdoor lighting, with indoor being a work-in-progress
- `

Complementary specifications



D4i specifications from DiiA:
DALI Part 250: Integrated bus power supply.
DALI Part 251: luminaire data for asset management.
DALI Part 252: energy reporting for drivers.
DALI Part 253: diagnostics & maintenance data for drivers.
Part 150/AUX power-supply specification.

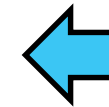
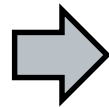

Book 18 specification from Zhaga:
Focus on outdoor lighting.
Ed 1.0 defines mechanical interface and electrical pin assignment.
Ed 2.0 adds references to D4i specifications for power and control, as well as luminaire tests.

Zhaga-D4i interface for outdoor luminaires

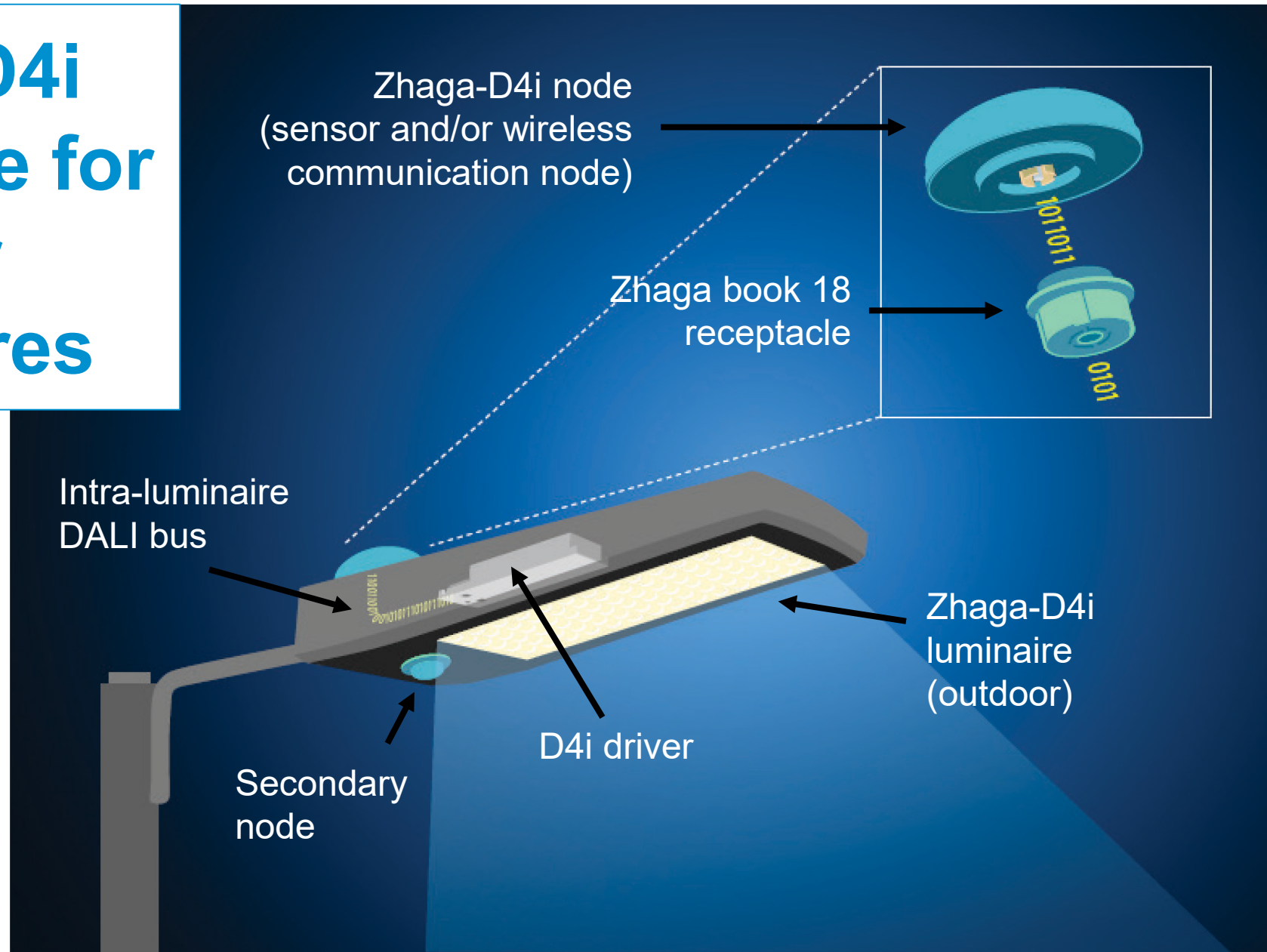

Use cases

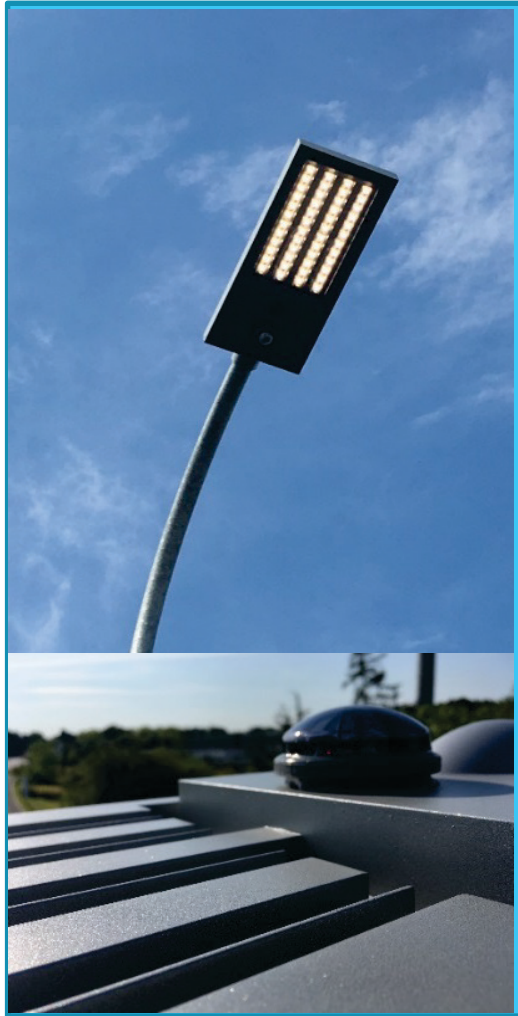

DOLL Living Lab //
Kopenhagen,
Denmark, Use case:
Dynamic Lighting //

23 LP

DIGITAL Darmstadt //
Darmstadt, Germany //
Use case: **Light on
Demand**

13 LP



100% Light Level @ 22W



6% Light Level – safe visibility @ 3.5W

Further background

- May 2019: Zhaga and DiiA unveil joint Zhaga-D4i certification program
 - Joint press release: <https://www.zhagastandard.org/features/276/diia-and-zhaga-start-cooperation-on-iiot-solutions-for-lighting>
 - Article from LED Professional
- May 2019: D4i brings standardization to intra-luminaire DALI
 - DiiA press release: www.digitalilluminationinterface.org/news/135/press-release-d4i-brings-standardization-to-intra-luminaire-dali
- February 2019: Zhaga confirms plan to transfer Book 18 to IEC
 - Zhaga press release: www.zhagastandard.org/features/280/zhaga-confirms-plan-to-transfer-book-18-to-iec
- January 2019: Zhaga and DiiA agree joint certification program for a smart luminaire interface
 - Joint press release: www.digitalilluminationinterface.org/news/123/press-release-zhaga-and-diia-agree-joint-certification-program-for-a-smart-luminaire-interface

